

QUANTUM<sup>®</sup>  
STORAGE  
SYSTEMS



**CONSUMER PRODUCTS**  
RETAIL STORAGE AND ORGANIZATION

# ULTRA STACK AND HANG BIN PACKS

## Ultra Stack and Hang Bin Packs



### PERFORMANCE FEATURES:

- Manufactured from heavy-duty polypropylene ensuring lifetime use.
- Front, back and side grips for easy handling.
- Built-in rear hanger allows bins to hang.
- Wide stacking ledge and anti-slide lock keep stacked bins steady and prevent forward shifting.
- Water, rust, and corrosion proof.
- Easily cleaned with soap and water and impervious to most chemicals.
- Large molded front label slots for ID labels.
- Perfect for garage, office, and warehouse.
- Guaranteed not to break or crack.



## QUANTUM IS CLEARLY YOUR STORAGE SOLUTION

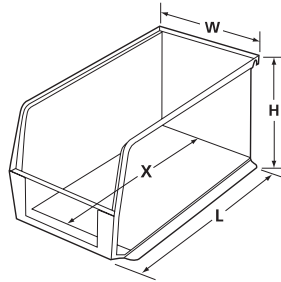

**Bin Dimensions Guide**  
**L** (length) **W** (width)  
**H** (height) **X** (inside length)



**12" Wall Mounted Rail**  
 2 of each included with each pack

Available in: ■ Blue ■ Red ■ Yellow

MODEL NO.	OUTSIDE DIMENSIONS L" x W" x H"	INSIDE DIMENSIONS L" x W" x H"	X"	BIN QTY	PKG WGT
<b>RQUS210</b>	5-3/8" x 4-1/8" x 3"	4-3/4" x 3-7/16" x 2-13/16"	4"	6	2 lbs
<b>RQUS230</b>	10-7/8" x 5-1/2" x 5"	10-1/4" x 4-3/8" x 4-3/4"	9"	4	3 lbs
<b>RQUS240</b>	14-3/4" x 8-1/4" x 7"	14" x 6-9/16" x 6-3/4"	12"	3	5 lbs

**EACH PACKAGE INCLUDES 2 - 12" HANGING RAILS.**



RQUS210



RQUS230



RQUS240

## Plastic Drawer Cabinets

- Heavy-Duty reinforced construction.
- See through drawers come with drawer dividers for every drawer.
- Stable stacking and mounting.
- Drawer stops prevents spills.
- Textured drawer pulls.
- Durable high impact polypropylene frame with clear polypropylene drawers and bins.

Available in: ■ Black & Gray

MODEL NO.	OUTSIDE DIMENSIONS L" x W" x H"	DRAWER/BIN QTY	DRAWER DIMENSIONS L" x W" x H"	PKG QTY	PKG WGT
<b>PDC-12BK</b>	6-1/4" x 10-1/2" x 10-1/4"	8 drawers 4 drawers	5-1/2" x 2" x 1-1/4" 5-1/2" x 4-1/4" x 2"	1	3 lbs
<b>PDC-18BK</b>	6-1/4" x 15" x 18-3/4"	18 drawers	5-1/2" x 4-1/4" x 2"	1	5 lbs
<b>PDC-22BK</b>	6-1/4" x 19-1/2" x 10"	14 drawers 8 drawers	5-1/2" x 2" x 1-1/4" 5-1/2" x 4-1/4" x 2"	1	5 lbs
<b>PDC-39BK</b>	6-1/4" x 15" x 18-3/4"	30 drawers 9 drawers	5-1/2" x 2" x 1-1/4" 5-1/2" x 4-1/4" x 2"	1	6 lbs
<b>PDC-60BK</b>	6-1/4" x 15" x 18-3/4"	60 drawers	5-1/2" x 2" x 1-1/4"	1	7 lbs
<b>PDC-930BK</b>	6-1/4" x 15" x 18-3/4"	30 drawers 9 bins	5-1/2" x 2" x 1-1/4" 5-1/2" x 4-1/4" x 2-3/4"	1	6 lbs



PDC-12BK



PDC-18BK



**EASY TO  
IDENTIFY  
ITEMS**



PDC-22BK



PDC-39BK



PDC-60BK



PDC-930BK

## Organizers

Clear lid design allows quick identification of parts inside. Unique latch design enables lid to close and latch tight and secure. Dividers prevent parts from migrating between various compartments. Base and lid manufactured from industrial grade polypropylene.

MODEL NO.	OUTSIDE DIMENSIONS L" x W" x H"	CTN QTY	CTN WGT
Single Sided			
ORG80032	12-1/2" x 10" x 2-1/4"	6	7 lbs
ORG81532	15" x 12-1/4" x 2-3/4"	6	11 lbs
ORG81832	18" x 14" x 3"	4	10 lbs
Double Sided			
ORG80322	12-1/4" x 10-1/4" x 3"	5	9 lbs



### ORG80032 Single Sided Organizer

- Offers up to 17 storage compartments.
- Includes 12 dividers allowing you to customize the size of the desired compartments inside.

## SINGLE SIDED



### ORG81532 Single Sided Organizer

- Offers up to 23 storage compartments.
- Includes 18 dividers allowing you to customize the size of the desired compartments inside.

## SINGLE SIDED



## DIVIDERS INCLUDED



### ORG81832 Single Sided Organizer

- Offers up to 26 storage compartments.
- Includes 21 dividers allowing you to customize the size of the desired compartments inside.

## SINGLE SIDED



### ORG80322 Double Sided Organizer

- Offers up to 32 storage compartments.
- Includes 24 dividers allowing you to customize the size of the desired compartments inside.

## DOUBLE SIDED

# CLEAR COMPARTMENT STORAGE BOXES

## Clear Compartment Storage Boxes

Utility boxes offer compartments for small and medium parts storage. Manufactured of clear, see-through polypropylene.



### RQB900

- Organizer has 10 fixed compartments.

MODEL NO.	OUTSIDE DIMENSIONS L" x W" x H"	CTN QTY	CTN WGT
<b>Removable Dividers</b>			
<b>QB200</b>	5-1/2" x 2-3/4" x 1-1/4"	12	2 lbs
<b>QB300</b>	6-3/4" x 4-3/4" x 2-1/4"	12	4 lbs
<b>QB400</b>	7-3/4" x 5-1/2" x 1-3/4"	12	5 lbs
<b>QB600</b>	9-1/4" x 6-1/4" x 2-1/5"	6	4 lbs
<b>QB800</b>	11-3/4" x 7-3/4" x 2-1/5"	6	5 lbs
<b>Fixed Dividers</b>			
<b>RQB900</b>	10-1/4" x 13" x 2-3/8"	6	8 lbs

UP TO **10** COMPARTMENTS  
FOR SMALL & MEDIUM  
SIZED PARTS



### QB200

- Can create from 3-8 compartments.



### QB300

- Can create from 1-6 compartments.



### QB400

- Can create from 2-8 compartments.



### QB600

- Can create from 1-8 compartments.



### QB800

- Can create from 1-10 compartments.

# CLEAR TIP OUT BINS AND INDIVIDUAL TIP OUT BINS

## Clear Tip Out Bins



## BIN CUPS KEEP SMALL ITEMS SORTED AND EASY TO FIND

These space saving bins are very handy for the garage, home, or office. Very efficient when it comes to organizing and keeping an effective inventory. Exterior cabinets manufactured of high impact polystyrene and clear bins of crystal styrene. All clear bins have a molded in label holder (labels included).

Available in:  Ivory  Gray  White

MODEL NO.	OUTSIDE DIMENSIONS L" x W" x H"	BIN DIMENSIONS L" x W" x H"	PKG QTY	PKG WGT
<b>QTB303</b>	7-3/4" x 23-5/8" x 9-1/2"	5-7/8" x 7-3/8" x 8-5/8"	1	9 lbs
<b>RQTB304</b>	6-5/8" x 23-5/8" x 8-1/8"	5" x 5-5/8" x 7-1/2"	1	7 lbs
<b>RQTB305</b>	5-1/4" x 23-5/8" x 6-1/2"	3-3/4" x 4-1/4" x 5-3/4"	1	5 lbs
<b>RQTB306</b>	3-5/8" x 23-5/8" x 4-1/2"	2-5/8" x 3-1/2" x 3-3/4"	1	2 lbs
<b>RQTB309</b>	2-1/2" x 23-5/8" x 3-1/8"	1-3/4" x 2-3/16" x 2-1/2"	1	2 lbs



RQTB309



RQTB306



RQTB305



RQTB304



RQTB669

### PERFORMANCE FEATURES:

- Space saving bin units keep small and medium sized parts organized, sorted and easy to find.
- Clear and break resistant injection molded plastic containers tip open smoothly to a 45° angle.
- Cups are completely removable for easy access and refilling.
- Molded handle with slots for labels provided.
- Bins are easily cleaned with soap and water.
- Polystyrene cabinet can be stacked or wall mounted.
- Exterior housing available in 3 colors.



TIP OUT  
TIP OUT  
TIP OUT  
TIP OUT  
BIN



RQTB409

### Individual Tip Out Bins



These unique bins have the ability to interlock horizontally or vertically. Available in three popular sizes, these bins allow you to create your own customized Tip Out Bin storage system perfect for color coding.

RQTB405 & RQTB406 available in:  Ivory  Gray  White

RQTB409 available in:  Blue  Red  Yellow  White

MODEL NO.	OUTSIDE DIMENSIONS L" x W" x H"	CTN QTY	CTN WGT
<b>RQTB405</b>	5-1/4" x 4-3/4" x 6-1/4"	5	6 lbs
<b>RQTB406</b>	3-5/8" x 4-1/16" x 4-1/4"	6	4 lbs
<b>RQTB409</b>	2-3/8" x 2-13/16" x 3"	9	3 lbs

### 669 Tip Out Bin Set



- 21 clear cups inside one unit.
- Clear cups with blue handles.

Available in:  Gray

MODEL NO.	OUTSIDE DIMENSIONS L" x W" x H"	BIN DIMENSIONS L" x W" x H"	CUP QTY	PKG QTY	PKG WGT
<b>RQTB669</b>	3-5/8" x 23-5/8" x 11-1/6"	2-5/8" x 3-1/2" x 3-3/4"	12	4	24 lbs
		1-3/4" x 2-3/16" x 2-1/2"	9		



# CROSS STACK TUBS

Cross Stack Tubs



Manufactured from approved USDA/FDA materials, tote nests when empty or can be turned 90° to cross stack. Easy access to items when stacked. Injection molded from durable, high impact polypropylene. Easy to clean. Built in handle grips and bottom grooves makes handling easy. Holds up to 100 lb. 1/4" drill hole pattern on bottom of bin allows for easy hole insertion for optional air flow and drainage.

Available in: ■ Blue ■ Gray □ White \* Also available in: ■ Red ■ Yellow

MODEL NO.	OUTSIDE DIMENSIONS L" x W" x H"	CAP GAL	CTN QTY	CTN WGT	LID	CTN QTY
<b>RTUB1711-8</b>	17-1/4" x 11" x 8"	3.85	6	14 lbs	<b>RLID1711</b>	6
<b>RTUB1711-12</b>	17-1/4" x 11" x 12"	5.51	6	17 lbs	<b>RLID1711</b>	6
<b>RTUB2417-8</b>	23-3/4" x 17-1/4" x 8"	9.81	6	25 lbs	<b>RLID2417</b>	6
<b>RTUB2417-12</b>	23-3/4" x 17-1/4" x 12"	14.38	6	30 lbs	<b>RLID2417</b>	6
<b>RTUB2516-8*</b>	25-1/8" x 16" x 8-1/2"	9.75	6	20 lbs	<b>RLID2516-8*</b>	6

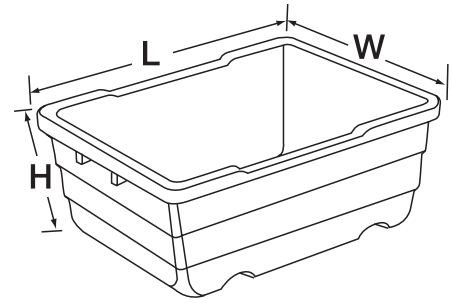

**Bin Dimensions Guide**  
L (length) W (width) H (height)



**RTUB2516-8\***  
Nesting and Cross Stacked



**RLID2516-8\***  
Optional lid keeps stored items dust free.  
Tubs can still stack or cross stack with lids in place.

## Latch Containers



**RLID1915 and RLID1915CL**  
Latch Container Lid

Quantum's new Latch Containers feature heavy-duty latches on each end that snap lock providing a tight and secure fit. Perfect for clothing, craft supplies, or office products. These durable and ultra-strong containers can hold up to 50 lbs. Injection molded from durable, high impact polypropylene. Lids feature reinforced ribs that allow totes to safely and securely stack on top of each other.

Available in:  Black  Clear

MODEL NO.	OUTSIDE DIMS L" x W" x H"	INSIDE TOP DIMS L" x W" x H"	INSIDE BOTTOM DIMS L" x W"	CAP GAL	CTN QTY	CTN WGT	LID	CTN QTY
<b>RLC191507</b>	21" x 15-7/8" x 7-3/4"	18-3/8" x 14-5/8" x 7-1/4"	15-7/8" x 12-7/8"	7.03	6	12 lbs	<b>RLID1915</b>	6
<b>RLC191507CL</b>	21" x 15-7/8" x 7-3/4"	18-3/8" x 14-5/8" x 7-1/4"	15-7/8" x 12-7/8"	7.03	6	12 lbs	<b>RLID1915CL</b>	6



**RLC191507CL and RLID1915CL**



**RLC191507CL**  
Nesting and Stacked with Lid



**HOLD UP TO  
50 lbs.**



**RLC191507 and RLID1915**

# GIANT STACK CONTAINERS

## Giant Stack Containers



Multipurpose, wide open hopper front provides easy access for large part storage. Ideal for multiple applications in recycling, storing parts and tools. These bins will stack up to 6 bins high creating a sturdy, tall storage system. Bins are injection molded from high density polypropylene, easy to clean, resist corrosion and are impervious to most chemicals. Large label holder allows for quick identification. Six 1/4" drill hole pattern on bottom of bin allow for easy hole insertion for drainage and air circulation.

RQGH700 available in: ■ Blue ■ Ivory ■ Red ■ Black ■ Gray ■ Clear

RQGH600 and RQGH800 available in: ■ Blue ■ Red ■ Gray ■ Clear

MODEL NO.	OUTSIDE DIMENSIONS L" x W" x H"	INSIDE DIMENSIONS L" x W" x H"	X"	CAP GAL	CTN QTY	CTN WGT
RQGH600	17-1/2" x 10-7/8" x 12-1/2"	15-5/8" x 8" x 12-1/4"	13-1/2"	7.33	4	12 lbs
RQGH700	15-1/4" x 19-7/8" x 12-7/16"	13-5/8" x 17-1/2" x 12-1/4"	11-1/2"	12.71	3	13 lbs
RQGH800	17-1/2" x 16-1/2" x 12-1/2"	15-5/8" x 13-3/4" x 12-1/4"	13-1/2"	11.97	2	8 lbs

### PERFORMANCE FEATURES:

- Extra thick side walls with reinforced rib designed for strength, allowing for 100 lb. stack capacity per bin.
- Large grip side handles.
- Stacks 6 bins high.
- Six 1/4" drill hole pattern on bottom of bin allows for easy hole insertion for drainage.



RQGH800



RQGH600

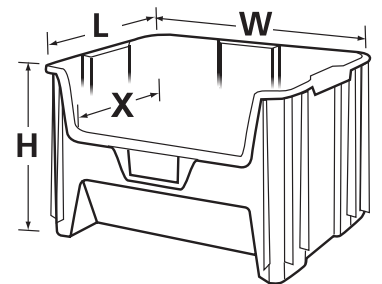

#### Bin Dimensions Guide

L (length) W (width) H (height)  
X (inside length)

Curved lip and corners provide added strength

Large and comfortable grip side handles allow for easy carrying and handling



Large label holder allows for quick part identification

RQGH700

Ribs on side of bin provide added stability when stacked

# WRENCH HOLDER, TOOL RACK AND NESTING PARTS BIN

## Wrench Holder



Versatile wrench holder can be mounted on a wall or can lay flat. Manufactured from industrial-strength polystyrene and can hold up to 15 wrenches of different sizes. Mounting hardware is not included.

Available in:  Black

MODEL NO.	OUTSIDE DIMENSIONS L" x W" x H"	CTN QTY	CTN WGT
RWH-15	1" x 7-1/8" x 11-5/8"	12	5 lbs



RWH-15

**HOLDS  
UP TO 15  
WRENCHES**

## Tool Rack



Space saving tool rack is manufactured from durable polypropylene. Get organized with this tough rack that will not warp or bend even when it is loaded to capacity. Holds up to 96 tools. 40 lb. weight capacity. Mounting holes are spaced for pegboards. Mounting hardware is not included.

Available in:  Red

MODEL NO.	OUTSIDE DIMENSIONS L" x W" x H"	CTN QTY	CTN WGT
RTR-96	6" x 24-1/8" x 2-3/4"	12	9 lbs

**HOLDS  
UP TO 96  
ITEMS**



RTR-96

**TOUGH,  
DURABLE,  
HIGH DENSITY**

## Economy All-Purpose Nesting Parts Bin



Organize your small to medium parts with our tough, durable, high density Nesting Parts Bins. Bins save space and nest when empty. Manufactured from heavy-duty polypropylene.

Available in:  White  Black

MODEL NO.	OUTSIDE DIMENSIONS L" x W" x H"	CTN QTY	CTN WGT
RNPB1076	10-1/4" x 7-1/2" x 6"	20	10 lbs



RNPB1076

# POLYMER UTILITY CARTS



Comfortable waist-high handle grip for easy pushing and handling

19" H

**PC4026-33**  
40"L x 26"W x 32-1/2"H

**CARTS OFFER**  
**550 lb.**  
**LOAD**  
**CAPACITY**



**PFTC4026-33-2**  
40"L x 26"W x 32-1/2"H



**PC3518-33**  
34-1/4"L x 17-1/2"W x 32-1/2"H

## Polymer Utility Carts

Industrial strength cart is ideal for any industrial or commercial application. Set of 2 swivel and 2 rigid 5" x 1-1/4" heavy-duty casters allow for 550 lb. load capacity. Manufactured from super strong structural foam.

Available in: ■ Gray

MODEL NO.	OUTSIDE DIMENSIONS L" x W" x H"	INSIDE SHELF DIMENSIONS L" x W" x H"	NO. OF SHELVES	SHIP WGT
<b>PC3518-33</b>	34-1/4" x 17-1/2" x 32-1/2"	29-1/4" x 15-1/4" x 2-5/8"	2	38 lbs
<b>PC4026-33</b>	40" x 26" x 32-1/2"	35" x 23" x 2-5/8"	2	54 lbs
Polymer Flat Top Shelf Cart				
<b>PFTC4026-33-2</b>	40" x 26" x 32-1/2"	35" x 23"	2	51 lbs

\* INSIDE DIMENSION FOR BOTTOM SHELF 35" x 23" x 2-5/8"

# TOOL CADDY AND TOOL BOX

## Tool Caddy



Industrial strength, hand-held caddy ideal for tools and supplies. This portable, high density polypropylene caddy has extra strength ribs for support. Deep compartments make transporting tools, supplies and loose parts easy.

Available in: ■ Blue ■ Gray

MODEL NO.	OUTSIDE DIMENSIONS L" x W" x H"	CTN QTY	CTN WGT
RTC500	13-7/8" x 18-3/8" x 9"	6	13 lbs

RTC500



Deep compartments are ideal for automotive parts, hardware or cleaning supplies

**RUGGED,  
DURABLE,  
HEAVY-DUTY**



Comfortable grip handle even when carrying heavy loads



Industrial-strength polypropylene

Perfect for tools, parts and janitorial supplies

## Tool Box



This tough tool box will not warp or bend even when it is loaded to capacity. Ideal for carrying hand tools, hardware or small to medium sized items. Handle provides comfortable smooth grip. Flush top surface for convenient stacking and storing. Manufactured from heavy-duty polypropylene.

Available in: ■ Red ■ Clear

MODEL NO.	OUTSIDE DIMENSIONS L" x W" x H"	CTN QTY	CTN WGT
RTB12	5-1/2" x 12" x 4-1/8"	12	9 lbs
RTB12CL	5-1/2" x 12" x 4-1/8"	12	9 lbs

**IDEAL FOR CARRYING  
HAND TOOLS**

**NEW**

RTB12



RTB12CL



# CONVENIENT 1 BOX WIRE PLASTIC MAT SHELVING UNITS

## Convenient 1 Box Wire Plastic Mat Shelving Units



4 shelf consumer grade wire plastic mat shelving unit. Super competitive cost. All packed in 1 box for super easy inventory control, shipping, and receiving.

Finishes available in: ■ Anti-Bacterial Blue

MODEL NO.	DIMENSIONS W" x L" x H"	SHIP WGT
RPWR72-1830E	18" x 30" x 72"	44 lbs
RPWR72-1836E	18" x 36" x 72"	49 lbs
RPWR72-1848E	18" x 48" x 72"	59 lbs
RPWR72-2430E	24" x 30" x 72"	57 lbs
RPWR72-2436E	24" x 36" x 72"	64 lbs
RPWR72-2448E	24" x 48" x 72"	77 lbs



Smooth, vented, open grid surface allows for air circulation and minimal dust buildup

## SUPER LOW PRICE



4 SHELF UNIT

### PERFORMANCE FEATURES:

- 600 lb. load capacity per shelf.
- Snap together design assembles in minutes.
- Smooth, vented, open grid surface allows for air circulation and minimal dust buildup.
- Plastic mats can be easily removed for cleaning and are dishwasher safe.
- Plastic material will never dent, chip, rust or corrode.
- Shelves easily adjust to your exact height needs.
- Ideal storage solution for any commercial or home application.
- Posts and frames are steel with anti-bacterial Blue finish.

### SINGLE BOX SHIPMENT

### SUPER LOW TRANSIT COST

### 600 lb. LOAD CAPACITY PER SHELF



- INCLUDED Inside the Box**
- 4 posts
  - 2 or 3 pieces each
  - 4 wire frames
  - 4 plastic wire mats
  - 2 or 3 pieces each
  - 4 packs of split sleeves
  - 4 pairs each



# CHROME CONVENIENT 1 BOX WIRE SHELVING UNITS

## Chrome Convenient 1 Box Wire Shelving Units



4 shelf consumer grade wire shelving unit. Super competitive cost. All packed in 1 box for super easy inventory control, shipping, and receiving.

Finishes available in:  Chrome

CHROME MODEL NO.	DIMENSIONS W" x L" x H"	SHIP WGT
RWR72-1830LD	18" x 30" x 72"	35 lbs
RWR72-1836LD	18" x 36" x 72"	38 lbs
RWR72-1842LD	18" x 42" x 72"	42 lbs
RWR72-1848LD	18" x 48" x 72"	46 lbs
RWR72-2430LD	24" x 30" x 72"	40 lbs
RWR72-2436LD	24" x 36" x 72"	46 lbs
RWR72-2442LD	24" x 42" x 72"	51 lbs
RWR72-2448LD	24" x 48" x 72"	56 lbs

**SUPER LOW PRICE**



4 SHELF UNIT  
Chrome Finish

### PERFORMANCE FEATURES:

- 300 lb. load capacity per shelf.
- Snap together design assembles in minutes.
- Wire design allows for air circulation and minimal dust buildup.
- Shelves easily adjust on 1" centers to your exact needs.
- Ideal storage solution for any commercial, office, warehouse or home application.
- Bright Chrome finish.
- Includes posts, shelves, and all needed hardware - all in one box.
- No tools required.



**SINGLE BOX SHIPMENT**

**SUPER LOW TRANSIT COST**

**300 lb.  
LOAD CAPACITY  
PER SHELF**

- INCLUDED Inside the Box**
- 4 posts (2 pieces each)
  - 4 wire shelves
  - 4 packs of split sleeves (4 pairs each)





## VISIT US ONLINE

to view our full product line

[WWW.QUANTUMSTORAGE.COM](http://WWW.QUANTUMSTORAGE.COM)

Our mission is to be your one stop source for bins, bin systems, totes, and wire shelving. Contact Quantum Storage Systems today and revolutionize the way you organize.

### CORPORATE OFFICE

15800 NW 15th Avenue  
Miami, Florida 33169

Toll Free **1-800-685-4665**

Phone (305) 687-0405

Fax (305) 688-2790

[sales@quantumstorage.com](mailto:sales@quantumstorage.com)