

GENUINE STACK AND NEST TOTES

**NEW
PRODUCT
BULLETIN**

9 SIZES AVAILABLE

These heavy-duty, tough, and dependable stack and nest totes are the ultimate reusable container for storing and transporting your valuable items in any application. These proven containers are available in nine sizes for efficiency and inventory control.

**NEW
CLEAR COLOR
AVAILABLE
NOW!**



snt230CL

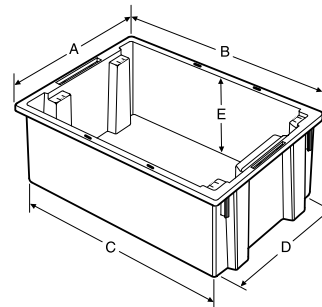

Bin Inside Dimensions Guide

- A (top width)
- B (top length)
- C (bottom length)
- D (bottom width)
- E (height)



snh010

All nine sizes of totes have ability to use the optional 3" x 5" clear label holder. It securely attaches to tote with or without lid for easy part identification.



AL-35

3" x 5" Clear Adhesive Label Holder & Inserts attaches securely to container for easy part identification. Package of 24.



Optional lid snaps on tightly and securely to protect container contents. As pictured, lids can be fastened and locked for added security.

CLEAR BINS
AVAILABLE IN CLEAR VIEW

Available in: Clear

MODEL NO.	OUTSIDE DIMENSIONS L" x W" x H"	A	B	INSIDE DIMENSIONS			CAPACITY (CU FT)	CTN QTY	CTN WGT	LID	CTN QTY	
				C	D	E						
snt180CL	18" x 11" x 6"	10"	16"	15-1/4"	9-3/8"	5-7/8"	0.50	6	12 lbs	LID181CL	6	
snt185CL	18" x 11" x 9"	10"	16"	15-1/8"	9-1/8"	8-7/8"	0.76	6	15 lbs	LID181CL	6	
snt190CL	19-1/2" x 15-1/2" x 10"	14-1/2"	17"	16"	13-1/4"	9-7/8"	1.20	6	23 lbs	LID191CL	6	
snt195CL	19-1/2" x 15-1/2" x 13"	14-1/2"	17"	15-7/8"	13-3/8"	12-7/8"	1.70	6	26 lbs	LID191CL	6	
snt200CL	19-1/2" x 13-1/2" x 8"	12-3/8"	17-7/8"	16-3/8"	11-1/2"	7-7/8"	0.80	6	19 lbs	LID201CL	6	
snt225CL	23-1/2" x 19-1/2" x 10"	18-1/4"	20-7/8"	19-3/8"	16-7/8"	9-7/8"	2.00	3	18 lbs	LID231CL	3	
snt230CL	23-1/2" x 19-1/2" x 13"	18-1/8"	20-7/8"	19-1/2"	16-7/8"	12-7/8"	2.60	3	22 lbs	LID231CL	3	
snt240CL	23-1/2" x 15-1/2" x 12"	14-1/4"	20-7/8"	19-5/8"	13"	11-7/8"	1.70	3	18 lbs	LID241CL	3	
snt300CL	29-1/2" x 19-1/2" x 15"	18-1/4"	26-5/8"	25-1/8"	16-5/8"	14-7/8"	3.70	3	31 lbs	LID301CL	3	
snh010	Clear Label Holder - 3" x 5" (Fits all tote sizes)								6	1 lb	-	-

PERFORMANCE FEATURES AND BENEFITS

- ▶ Totes are injection molded from high-density polypropylene material that complies with the USDA and FDA regulations
- ▶ stack and nest totes will not corrode, bend out of shape, are unaffected by chemicals and are waterproof
- ▶ Reusable container will stack with or without lids for maximum storage and shipping
- ▶ snt's have the unique ability to stack or they can be turned 180° to nest when empty saving valuable space
- ▶ Optional lids for totes can be secured with nylon ties
- ▶ Textured bottoms ensure safe and easy, non-slip grip in transit on conveyors

THE MOST EFFICIENT, PERMANENT, AND ECONOMICAL SOLUTION TO SOLVE YOUR EXACT STORAGE NEEDS!



CORPORATE HEADQUARTERS

15800 NW 15th Avenue Miami, Florida 33169
Toll-Free 1-800-685-4665 Fax 305-688-2790

sales@quantumstorage.com www.quantumstorage.com

