

# PRODUCT SPOTLIGHT

## expandable EZ lock pallet & platform



EASILY STORE SUPPLIES & MATERIALS OFF THE GROUND.

### Expandable EZ Lock Pallet & Platform



Quantum's NEW EZ Lock Pallet and Dunnage platform allows you to customize your storage space in seconds. Its patented interlocking design allows true flexibility in building the exact size pallet or platform you need. Using 12" x 40" footprints, each unit locks together making this an all purpose storage, moving, and shipping solution. Manufactured of recycled high density polyethylene, the vented deck is freezer safe and chemical resistant. Its one piece body design and structure allows for a 4 way forklift and hand truck entry, and it meets GMA industry standards. Enhances any 5S Lean initiative. Withstands temperatures from -30° F – 200° F and offers a 2,500 lb load capacity. Once built, the structure will maintain its dimensions with no sagging or stretching. Plastic will not absorb any liquids or chemicals and is resistant to insect infestation. Perfect for use in hospitals, pharmacies, clean rooms, food and beverage areas, manufacturing environments, and supermarket and grocery store back rooms. **Color:** Black

MODEL NO.	DIMENSIONS W" x L" x H"	CTN QTY	SHIP WGT
EL-12406	12" x 40" x 6"	1 Pair (2 Pieces)	12 lbs

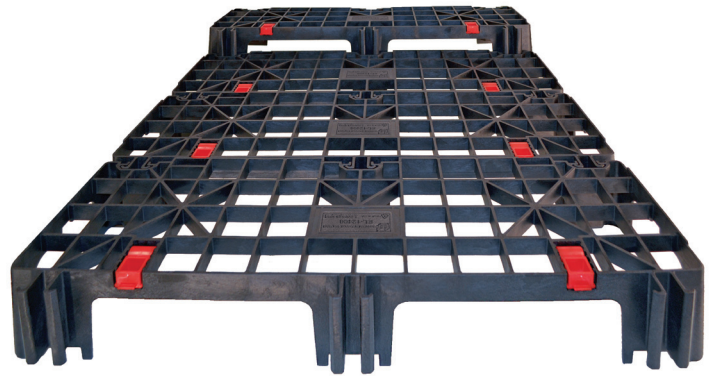

**QUICK & TROUBLE FREE ASSEMBLY!**  
2,500 lbs load capacity!

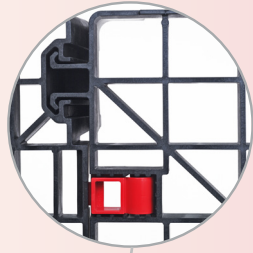
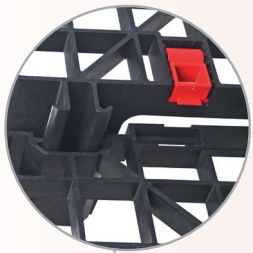

### LOCKING SYSTEMS

Simple locking system allows for quick and trouble-free assembly

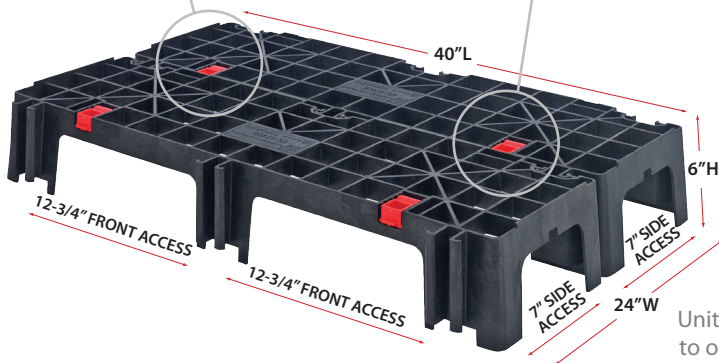

### EL-12406

12"W x 40"L x 6"H  
**Two Unit Assembly**

Unit can be built to any 12" increment to organize, ship, move or store items  
(Sold in pairs, 2 pieces)



**EXPANDABLE! UNBREAKABLE! REUSABLE!**

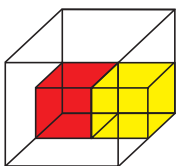

**QUANTUM<sup>®</sup>  
STORAGE  
SYSTEMS**

15800 NW 15th Avenue, Miami, FL 33169

**TOLL-FREE:** (800) 685-4665 **TEL:** (305) 687-0405

**FAX:** (305) 688-2790 **E-MAIL:** sales@quantumstorage.com

**www.quantumstorage.com**